

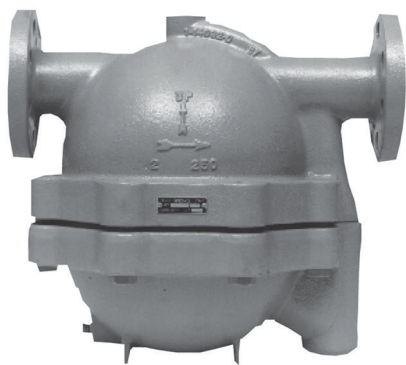

## YARWAY FXT700 SERIES VARIABLE ORIFICE STEAM TRAPS

### FREE FLOAT MECHANICAL STEAM TRAP



#### INTRODUCTION

A steam trap is an automatic valve which discharges condensate, undesirable air and non-condensibles from a system while trapping, or holding in, steam.

The FXT700 Series are float and thermostatic steam traps. Float is free of levers, linkages or other mechanical connections. This float is weighted to maintain orientation and acts as the valve being free to modulate condensate through the seat ring. Air vent is balanced-pressure design with stainless steel welded encapsulated bellows capable of discharging air and non-condensable gases continuously within 15°F (-9.4°C) of saturated temperature. Trap contains integral strainer and stainless steel exhaust port sleeve.

#### FEATURES

- All Stainless Steel Internal Components – Hardened valves and seats. Extra long life and dependable service. Resists water hammer. Protects against erosion and corrosion.
- Erosion Proof – Discharge passage is protected with a stainless steel liner.
- Integral Strainer – Stainless Steel screen prevents dirt problems. Blow-down connection provided.
- Thermostatic Air Vent – Provided with balanced pressure element for immediate and complete air venting.
- Variable Orifice – Condensate is discharged continuously through the seat ring which is modulated by the float. This provides a smooth, even flow without high velocity or steam entrainment.
- SLR Orifice – Optional continuous bleed prevents flash steam lockup when it is impossible to install trap at low point in system.

#### SPECIFICATIONS

The Specifications section gives some general specifications for the FXT700 Series variable orifice steam traps. The nameplates give detailed information for a specific steam trap as built in the factory.

Available Configurations:	Type FXT701 (Low capacity); Type FXT702 (Medium capacity); Type FXT703 (High capacity)
Body Sizes:	NPS ½, ¾, 1, 1½ and 2 (DN 15, 20, 25, 40 and 50)
End Connection Styles:	SWE, NPT, CL300 RF and CL600 RF

Maximum Operating Pressure <sup>(1)</sup> :	See Table 1
Maximum Allowable Temperature <sup>(1)</sup> :	750°F (400°C)
Maximum Allowable Pressure <sup>(1)</sup> :	650 psig (44.8 bar)
Capacity Information:	See Tables 2 and 3
Option:	SLR Orifice Blowdown Valve Continuous Bleed Air Vent CL300 RF and CL600 RF Flanged Connection <sup>(2)</sup>
Applications:	Steam Lines Process Equipment Steam Cookers Steam Heated Vats Pressing Machinery Unit Heaters Oil Pre-heaters Converters Coils Rotating Drum
Approximate Weights:	21 to 195 lbs (9.5 to 88.6 kg)

1. The pressure/temperature limits in this Datasheet and any applicable standard or code limitation should not be exceeded.

2. Available on Types FXT702 and FXT703 only.

# YARWAY FXT700 SERIES VARIABLE ORIFICE STEAM TRAPS

## FREE FLOAT MECHANICAL STEAM TRAP

### PRINCIPLE OF OPERATION

On startup, the thermostatic air vent (caged stainless welded bellows) is open, allowing air to flow freely through the vent valve orifice. When condensate flows into the trap, the float rises, allowing condensate to be discharged. Once air and non-condensables have been evacuated, hot condensate will cause the thermostatic vent to close. Condensate will continue to be discharged as long as condensation occurs. During normal operation, an increase in the load causes the liquid level in the trap to rise. The float then rises and rolls off the seat ring, allowing more condensate to flow out. The float sinks as the condensate load decreases, moving nearer to the seat ring, decreasing the effective size of the orifice and allowing less condensate to discharge. This provides smooth, continuous operation that reacts instantly to load variation while maintaining a water seal over the seat ring to prevent live steam loss.

### INSTALLATION

Install the FXT700 Series Steam Trap upright and in a horizontal line with the arrow on the body pointing in the direction of flow. Allowable inclination is 5° or less horizontally and 5° or less at right angles to the plane of the pipe line.

### ORDERING INFORMATION

When ordering, complete the ordering guide on this page. Refer to the Specifications section. Review the description to the right of each specification and the information in each referenced table or figure. Specify your choice whenever a selection is offered.

### ORDERING GUIDE

#### Available Configurations (Select One)

- Type FXT701
- Type FXT702
- Type FXT703

#### Body Sizes (Select One)

- NPS ½ (DN 15)
- NPS ¾ (DN 20)
- NPS 1 (DN 25)
- NPS 1½ (DN 40)
- NPS 2 (DN 50)

#### End Connection (Select One)

- SWE
- NPT
- CL300 RF (For Types FXT702 and FXT703 only)
- CL600 RF (For Types FXT702 and FXT703 only)

#### Options

- SLR Orifice
- Blowdown Valve
- Orifice Continuous Bleed Air Vent

**TABLE 1. MAXIMUM OPERATING PRESSURE**

Orifice	Maximum Operating Pressure	
	psig	bar
20	20	1.4
50	50	3.5
100	100	6.9
150	150	10.3
175	175	12.1
250	250	17.2
300	300	20.7
400	400	27.6
600	600	41.4

# YARWAY FXT700 SERIES VARIABLE ORIFICE STEAM TRAPS

## FREE FLOAT MECHANICAL STEAM TRAP

**TABLE 2. MAXIMUM CAPACITY - LBS/HR 10°F BELOW SATURATION**

TYPE	ORIFICE, in.	MAX. ΔP, psig	DIFFERENTIAL PRESSURE, psig															
			1	5	10	20	50	75	100	150	175	200	250	300	400	500	600	
FXT701	0.277	20	590	1600	2100	2450	----	----	----	----	----	----	----	----	----	----	----	----
	0.209	50	340	760	1080	1540	2460	----	----	----	----	----	----	----	----	----	----	----
	0.157	100	200	500	650	830	1100	1300	1400	----	----	----	----	----	----	----	----	----
	0.141	150	170	385	527	705	990	1130	1240	1415	----	----	----	----	----	----	----	----
	0.130	175	180	350	500	675	900	1000	1100	1300	1400	----	----	----	----	----	----	----
	0.120	250	110	255	360	500	700	800	900	1000	1050	1100	1200	----	----	----	----	----
	0.106	300	105	240	330	435	575	675	750	875	955	1020	1140	1255	----	----	----	----
	0.096	400	100	220	300	390	510	585	640	740	795	835	920	1000	1140	----	----	----
	0.081	600	75	145	180	225	300	340	375	435	465	490	540	585	665	740	800	----
FXT702	0.593	20	2720	6280	8600	11,700	----	----	----	----	----	----	----	----	----	----	----	----
	0.469	50	1750	3920	5560	7900	12,600	----	----	----	----	----	----	----	----	----	----	----
	0.339	100	930	2170	3130	4460	6020	7030	7960	----	----	----	----	----	----	----	----	----
	0.316	150	850	1935	2650	3540	4970	5685	6230	7100	----	----	----	----	----	----	----	----
	0.297	175	800	1700	2300	3200	4400	5000	5500	6400	6900	----	----	----	----	----	----	----
	0.261	250	670	1400	1900	2540	3500	4100	4200	5100	5300	5500	6000	----	----	----	----	----
	0.238	300	645	1240	1565	1955	2575	2940	3220	3740	4000	4220	4640	5060	----	----	----	----
	0.213	400	515	995	1250	1565	2060	2355	2575	2995	3200	3380	3720	4050	4600	----	----	----
	0.180	600	370	710	895	1120	1470	1680	1840	2140	2290	2410	2655	2890	3300	3655	3955	----
FXT703	1.102	20	8000	15,000	18,000	22,800	----	----	----	----	----	----	----	----	----	----	----	----
	0.875	50	5460	12,600	15,600	18,400	25,400	----	----	----	----	----	----	----	----	----	----	----
	0.593	100	2800	6350	8700	12,800	16,600	18,700	21,000	----	----	----	----	----	----	----	----	----
	0.578	150	2690	6120	8385	11,200	15,700	17,980	19,700	22,450	----	----	----	----	----	----	----	----
	0.547	175	2400	5500	7600	10,300	14,400	16,500	18,200	20,750	21,900	----	----	----	----	----	----	----
	0.484	250	1600	3770	5300	7560	10,400	12,100	13,600	15,500	16,300	17,100	18,400	----	----	----	----	----
	0.453	300	1500	3500	5200	7075	9325	10,655	11,655	13,545	14,485	15,275	16,815	18,315	----	----	----	----
	0.404	400	1400	2800	4200	5630	7420	8480	9270	10,770	11,520	12,150	13,380	14,570	16,555	----	----	----
	0.339	600	800	1800	2800	3900	5220	5970	6530	7585	8110	8555	9420	10,260	11,655	12,960	13,990	----

**TABLE 3. MAXIMUM CAPACITY - KG/HR 5°C BELOW SATURATION**

TYPE	ORIFICE, mm	MAX. ΔP, bar	DIFFERENTIAL PRESSURE, barg															
			0.07	0.35	0.69	1.38	3.5	5.17	6.90	10.3	12.1	13.8	17.2	20.7	27.6	34.5	41.4	
FXT701	7.04	1.38	268	726	953	1111	----	----	----	----	----	----	----	----	----	----	----	----
	5.31	3.45	154	345	490	699	1116	----	----	----	----	----	----	----	----	----	----	----
	3.99	6.90	91	227	295	376	499	590	635	----	----	----	----	----	----	----	----	----
	3.58	10.34	77	175	239	320	449	513	562	642	----	----	----	----	----	----	----	----
	3.30	12.07	82	159	227	306	408	454	499	590	635	----	----	----	----	----	----	----
	3.05	17.24	50	116	163	227	318	363	408	454	476	499	544	----	----	----	----	----
	2.69	20.69	48	109	150	197	261	306	340	397	433	463	517	569	----	----	----	----
	2.44	27.58	45	100	136	177	231	265	290	336	361	379	417	454	517	----	----	----
	2.06	41.37	34	66	82	102	136	154	170	197	211	222	245	265	302	336	363	----
FXT702	15.06	1.38	1234	2849	3901	5307	----	----	----	----	----	----	----	----	----	----	----	----
	11.91	3.45	794	1778	2522	3583	5715	----	----	----	----	----	----	----	----	----	----	----
	8.61	6.90	422	984	1420	2023	2731	3189	3611	----	----	----	----	----	----	----	----	----
	8.03	10.34	386	878	1202	1606	2254	2579	2826	3221	----	----	----	----	----	----	----	----
	7.54	12.07	363	771	1043	1452	1996	2268	2495	2903	3130	----	----	----	----	----	----	----
	6.63	17.24	304	635	862	1152	1588	1860	1905	2313	2404	2495	2722	----	----	----	----	----
	6.05	20.69	293	562	710	887	1168	1334	1461	1696	1814	1914	2105	2295	----	----	----	----
	5.41	27.58	234	451	567	710	934	1068	1168	1359	1452	1533	1687	1837	2087	----	----	----
	4.57	41.37	168	322	406	508	667	762	835	971	1039	1093	1204	1311	1497	1658	1794	----
FXT703	27.99	1.38	3629	6804	8165	10,342	----	----	----	----	----	----	----	----	----	----	----	----
	22.23	3.45	2477	5715	7076	8346	11,521	----	----	----	----	----	----	----	----	----	----	----
	15.06	6.90	1270	2880	3946	5806	7530	8482	9526	----	----	----	----	----	----	----	----	----
	14.68	10.34	1220	2776	3803	5080	7122	8156	8936	10,183	----	----	----	----	----	----	----	----
	13.89	12.07	1089	2495	3447	4672	6532	7484	8256	9412	9934	----	----	----	----	----	----	----
	12.29	17.24	726	1710	2404	3429	4717	5489	6169	7031	7394	7757	8346	----	----	----	----	----
	11.51	20.69	680	1588	2359	3209	4230	4833	5287	6144	6570	6929	7627	8308	----	----	----	----
	10.26	27.58	635	1270	1905	2554	3366	3847	4205	4885	5225	5511	6069	6609	7509	----	----	----
	8.61	41.37	363	816	1270	1769	2368	2708	2962	3441	3679	3881	4273	4654	5287	5879	6346	----

# YARWAY FXT700 SERIES VARIABLE ORIFICE STEAM TRAPS

## FREE FLOAT MECHANICAL STEAM TRAP

FIGURE 1

**FXT700 Series Variable Orifice Steam Trap Dimensions**

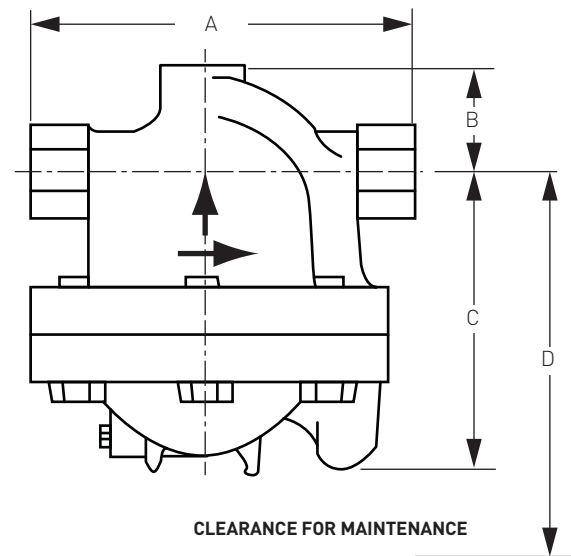

**TABLE 4. FXT700 SERIES DIMENSION**

TYPE	SIZE, NPS (DN)	A, in. (mm)			B, in. (mm)	C, in. (mm)	D, in. (mm)	WEIGHT, lbs (kgs)
		NPT	CL300 RF	CL600 RF				
FXT701	1/2, 3/4 and 1 (15, 20 and 25)	5 1/2 (140)	----	----	3 1/16 (78)	5 7/16 (138)	7 1/4 (84)	21 (9.5)
FXT702	1 (25)	11 (279)	13 3/4 (349)	13 3/4 (349)	2 15/16 (75)	8 3/4 (222)	11 3/8 (290)	84 (38.2)
	1 1/2 and 2 (40 and 50)	11 (279)	13 3/4 (349)	14 7/16 (349)	2 15/16 (75)	8 3/4 (222)	11 3/8 (290)	87 (39.5)
FXT703	1 1/2 (40)	13 3/4 (349)	16 3/4 (426)	17 3/8 (392)	3 3/16 (84)	11 1/8 (302)	16 (406)	192 (87.3)
	2 (50)	13 3/4 (349)	16 1/16 (424)	17 7/16 (443)	3 9/16 (84)	11 1/8 (302)	16 (406)	195 (88.6)

VCTDS-16915-EN © 2021, 2022 Emerson Electric Co. All rights reserved 07/22. Yarway is a mark owned by one of the companies in the Emerson Automation Solutions business unit of Emerson Electric Co. The Emerson logo is a trademark and service mark of Emerson Electric Co. All other marks are the property of their prospective owners.

The contents of this publication are presented for informational purposes only, and while every effort has been made to ensure their accuracy, they are not to be construed as warranties or guarantees, express or implied, regarding the products or services described herein or their use or applicability. All sales are governed by our terms and conditions, which are available upon request. We reserve the right to modify or improve the designs or specifications of such products at any time without notice.

Emerson Electric Co. does not assume responsibility for the selection, use or maintenance of any product. Responsibility for proper selection, use and maintenance of any Emerson Electric Co. product remains solely with the purchaser.